

Designing LC Wilkinson power splitters

Wilkinson power splitters are common transmission path elements. Designers can implement them more effectively by knowing their nuances.

By **Fernando Noriega,**
Pedro J. González

Microwave power splitters/combiners, such as Wilkinson dividers and hybrid rings, are commonly used, mainly in microstrip circuits¹. Some of their applications include balanced amplifiers, high-power transmitters, and antenna array feed networks.

These power splitters generally employ quarter-wave transmission line sections at the design center frequency, which can have unrealistic dimensions at frequencies in the RF and low microwave bands, where the wavelength is large.

For example, a $\lambda/4$ microstrip line with characteristic impedance $Z_0 = 70.7\Omega$ on FR-4 substrate (dielectric constant $\epsilon_r = 4.3$, thickness $h = 1.0$ mm) is approximately 43 mm long at a frequency of 1 GHz.

In some cases, it would be preferable to use lumped-element equivalent networks replacing the $\lambda/4$ transmission lines^{2,3}. It is possible to employ surface mount devices (SMD), as well as monolithic microwave integrated circuit (MMIC) lumped elements⁴, which allow saving circuit area.

Lumped element equivalents

As it is known, a $\lambda/4$ transmission line segment admits “Tee” and “Pi” lumped-element equivalent

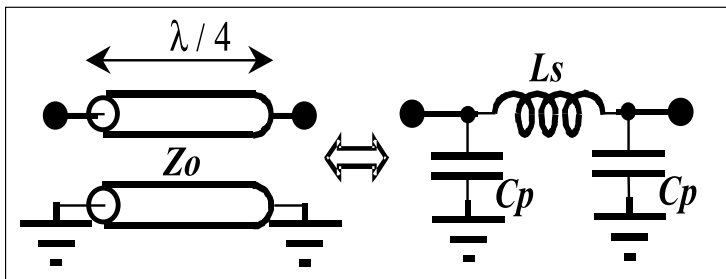

Figure 1. Lumped element “Pi” equivalent network of a $\lambda/4$ transmission line section

networks. The same is valid for a $3\lambda/4$ line segment. In particular, a quarter-wave line at a frequency f_0 , with characteristic impedance Z_0 , can be replaced for a “Pi” LC equivalent network as shown in Figure 1.

The element values are given by the following equations:

$$C_p = \frac{1}{2 \cdot \pi \cdot f_0 \cdot Z_0} \quad (1)$$

$$L_s = \frac{Z_0}{2 \cdot \pi \cdot f_0} \quad (2)$$

The “Pi” LC network is perfectly equivalent to the line section only at the center frequency f_0 , but the approximation is still valid for modest bandwidths.

Design of lumped-element Wilkinson dividers

Figure 2 shows the layout of a classical microstrip Wilkinson power splitter. In the simplest form, it consists of two quarter-wave line segments at the center frequency f_0 with characteristic impedance $Z_0 \cdot \sqrt{2}$, and a $2 \cdot Z_0$ lumped resistor connected between the output ports. It provides low loss,

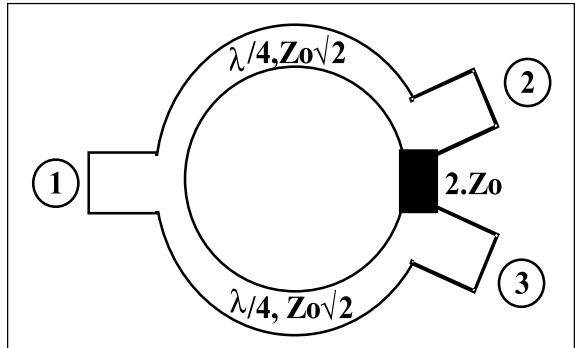

Figure 2. Layout of a classical microstrip Wilkinson power splitter.

equal split (ideally 3 dB), matching at all ports, and high isolation between output ports.

By replacing both $\lambda/4$ line sections by equivalent Pi LC networks, it is possible to obtain a lumped-element version of the Wilkinson divider, as shown in Figure 3. As noted above, this network is equivalent to the original only at the center frequency f_0 . Consequently, the expected performance (insertion loss, return loss, isolation, etc.) should be similar to that exhibited by the distributed-form power divider for a narrow bandwidth centered in f_0 , wide enough for most applications.

Moreover, the Pi LC equivalent networks exhibit a low-pass behavior, rejecting high frequencies, while the response of the classical Wilkinson divider repeats at odd multiples of center frequency ($3f_0$ and $5f_0$, mainly). This behavior could be desir-

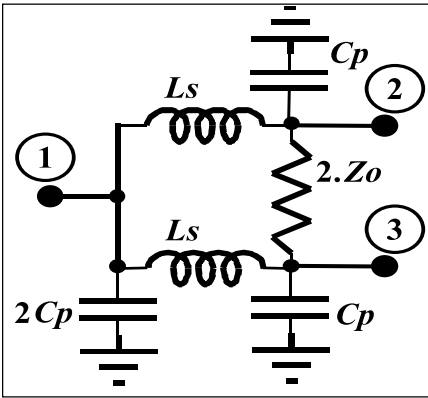

Figure 3. Schematic of the two-way lumped-element Wilkinson divider.

able if harmonic filtering is needed. For comparison purposes, Figure 4 shows the split, matching and isolation characteristics expected for these two types of Wilkinson dividers.

At 1080 MHz, using (1) and (2) we obtain $C_p = 1.8$ pF and $L_s = 10$ nH. At port 1 we choose a 3.9 pF capacitor, and the balancing resistor is 100Ω. In all cases, standard low-cost 0805 SMD components are used, featuring 5 percent tolerance.

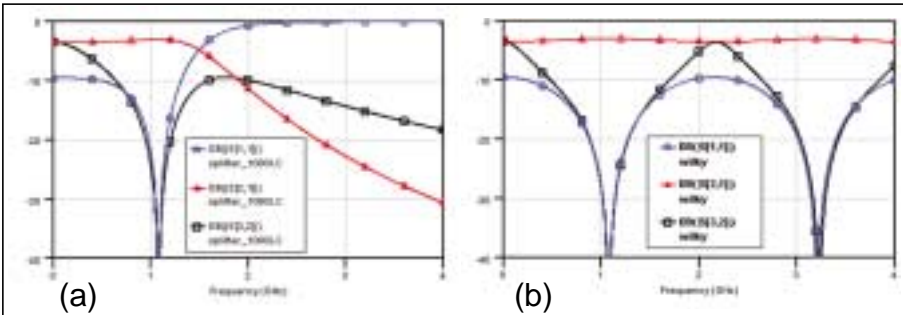

Figure 4. Comparison of simulated performance of a microstrip Wilkinson power splitter (a), and its lumped-element equivalent (b).

Measurement results are presented in Figure 5. Insertion loss at center frequency is about 3.6 dB, return losses result 14 dB at port 1, 16 dB at ports 2 and 3 (not shown), and isolation between output ports reaches 20 dB. These are typical values also attainable with a microstrip power divider. However, a 1 GHz microstrip Wilkinson splitter could occupy about 6 square centimeters on FR-4, while this lumped-element version occupies less than 1 square centimeter.

The actual behavior at higher frequencies differs expectations because device parasitics were neglected in the simulations. Nonetheless, second and third harmonics are still rejected more

than 25 dB. Better agreement could be achieved by considering an adequate modeling of device parasitics.

Three-way Wilkinson power splitter

The Wilkinson divider can be generalized to an N -way power splitter/combiner. For example, the diagram corresponding to a three-way divider is shown in Figure 6. As can be seen, it requires crossovers for the balancing resistors¹. This makes fabrication difficult in planar form (e.g.: microstrip). However, the lumped-element design is much easier to realize (see Figure 7). The board layout is depicted in Figure 8.

For an 850 MHz design, we can obtain $C_p = 1.5$ pF and $L_s = 15$ nH. At port 1, we choose a 4.7 pF capacitor, and the three balancing resistors are 51Ω. The shunt capacitor C_o is used to tune out the resistor and pad parasitics to avoid performance degradation (mainly in terms of isolation between ports). Its value is determined experimentally, varying typically in the 0.5 to 2 pF range for these frequencies.

Figure 9 presents the measured performance provided by the prototype.

Return losses are better than 12 dB at port 1 at center frequency (around 15 dB at output ports, not shown for clarity). Measured split losses from port 1 to

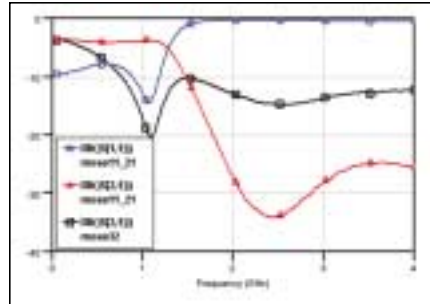

Figure 5. Measurements of the 1080 MHz lumped-element Wilkinson divider.

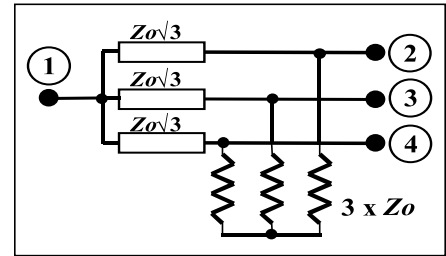

Figure 6. Diagram of a three-way Wilkinson divider.

all three output ports are only about 0.7 to 1.2 dB higher than in the ideal case (4.77 dB). Excellent isolation characteristics between the output ports, exceeding 25 dB, are achieved by adjusting the value of capacitor C_o .

Unequal Wilkinson power splitter

It is also possible to design power dividers with unequal power split and matching at all three ports². In Figure 10, transmission lines 3 and 4 are quarter-wave transformers used to match output ports to 50Ω. This would lead to a lumped-element design consisting of additional LC components. However, in some cases it may be feasible to simplify the circuit configuration (i.e., to reduce the component count) by removing some non-critical elements without noticeably degrading the performance characteristics.

For a center frequency of 850 MHz, an unequal Wilkinson power splitter with output power split ratio of 8 dB was designed. In Figure 11, the final circuit schematic is presented. This topology was obtained after empirically tuning the initial circuit elements and detecting which of them were essential to preserve acceptable split, matching and isolation characteristics over the desired bandwidth. The final element values are listed in Table 1. In particu-

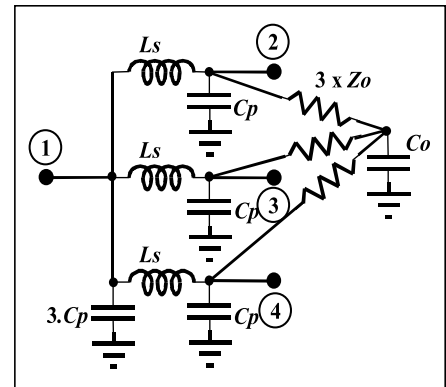

Figure 7. Schematic of the three-way lumped-element Wilkinson divider.

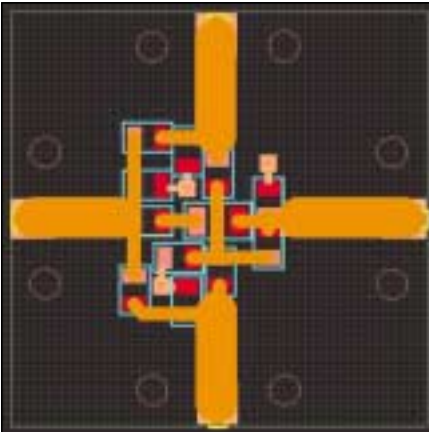

Figure 8. Layout of the three-way lumped-element Wilkinson divider.

Part	Value	Part	Value
$C1$	2.2 pF, 5% tol.	$L1$	47 nH, 5% tol.
$C2$	4.7 pF, 5% tol.	$L2$	6.8 nH, 5% tol.
$C12$	5.6 pF, 5% tol.	$L3$	8.2 nH, 5% tol.
R_i	150 Ω , 5% tol.		

Table 1. List of components for the unequal power splitter.

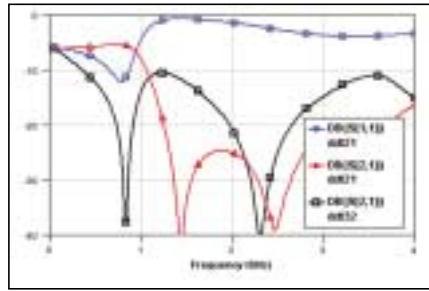

Figure 9. Measurements of the three-way lumped-element Wilkinson divider.

lar, resistor R_i must be selected to provide good isolation level.

Measurement results are plotted in Figure 13. Insertion losses are 10.5 dB and 1.3 dB for ports 2 and 3, respectively, thus corresponding to a split ratio of 9 dB. An excellent isolation value is achieved, better than 20 dB. On the other hand, matching results are quite good, except at port 2, where return loss is worse than 10 dB. If this value is not acceptable, it should be developed as a less simplified circuit

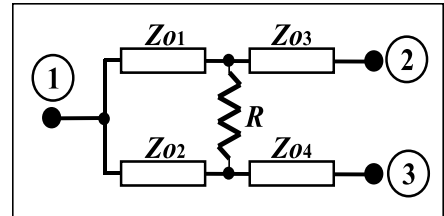

Figure 10. Diagram of an unequal Wilkinson power splitter.

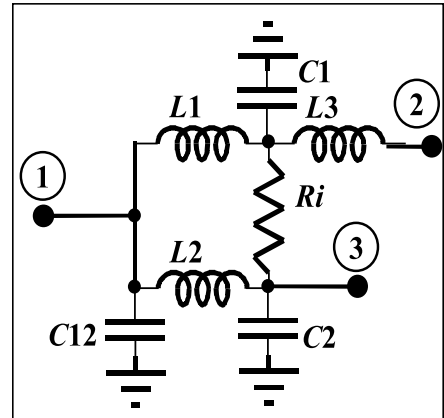

Figure 11. Schematic of the simplified lumped-element unequal Wilkinson power splitter.



Figure 12. Photograph of the unequal Wilkinson power splitter.

configuration, comprising additional LC elements.

Summary

Lumped-element Wilkinson power splitters can be used to replace the classical microstrip realization at frequencies from RF to several GHz, where quarter-wave line segments become large.

Several power splitters (two-, three-way, unequal split) employing low-cost SMD passive components have been designed in the 1 GHz band, pro-

viding excellent performance, similar to that expected for a transmission line divider for a modest bandwidth. They are also compact, allowing reduced circuit dimensions, and exhibiting a low pass behavior (not repeated at odd multiples of the center frequency), filtering the harmonic components of the input signal.

RF

References

- [1] David Pozar, "Microwave Engineering," Addison-Wesley, 1993.
- [2] Peter Vizmuller, "The RF Design Guide," Artech House, 1995.
- [3] Norm Dye and Helge Granberg, "Radio Frequency Transistors, Principles and Practical Applications," Butterworth-Heinemann, 1993.
- [4] V. F. Fusco, S.B.D. O'Caireallain, "Lumped Element Hybrid Networks for GaAs MMICs," Microwave and Optical Technology Letters, Vol. 2, No. 1, Jan. 1989.

About the authors

Fernando Noriega is a development engineer in ACORDE S.A., where he is involved in design and development of DC to microwave circuits and systems. He received his Telecommunication Technical Engineer degree from the University of Cantabria, Spain, in 2000.

Pedro J. González is a managing director of ACORDE S.A. He manages several RF and Microwave R&D projects including frequency converters and solid-state power amplifiers. He received his Telecommunication Engineer degree from the University of Cantabria, Spain, in 1999. The authors can be reached at: fnoriega@acordec.com and pedroj@acordec.com, or www.acordec.com